

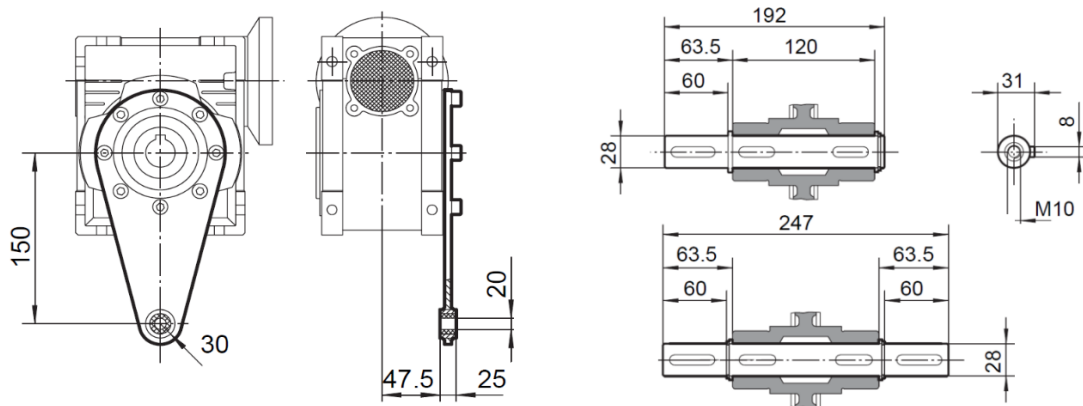

Worm Gear Units

TCNDK75

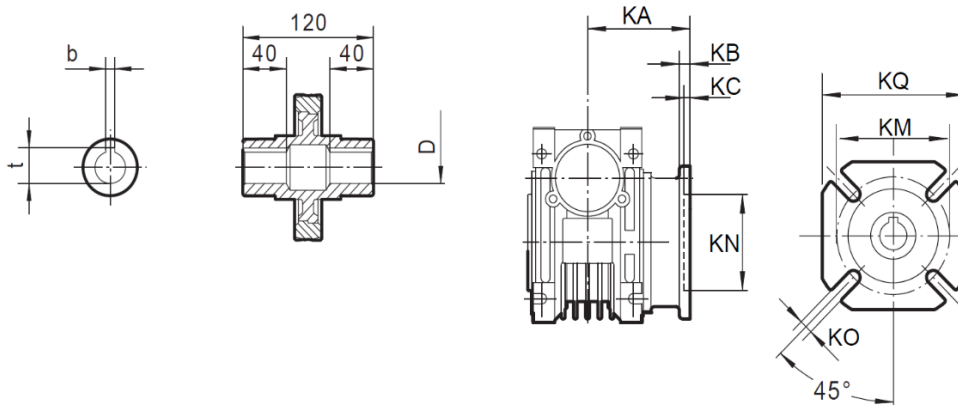
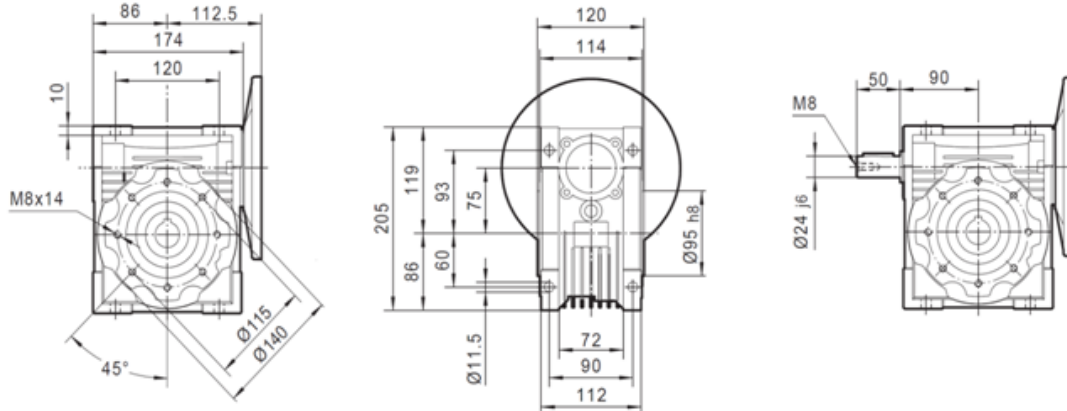

Input Motor Flange Dimensions							
IEC	71B5	80B14	80B5	90B14	90B5	100B14	100B5
D	14	19	19	24	24	28	28
P	160	120	200	140	200	160	250
M	130	100	165	115	165	130	215
N	110	80	130	95	130	110	180

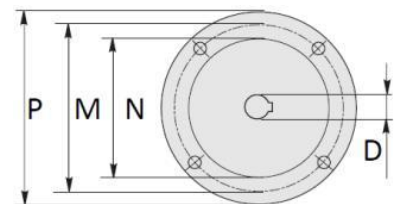

Weight without motor = 9.0 Kg